

# QUICK INSTALLATION GUIDE <G071-7503B>

Please read the Safety Information in Maintenance Guide 1 before using this machine. It contains important information related to USER SAFETY and PREVENTING EQUIPMENT PROBLEMS.



## WHERE TO PUT THE PRINTER

The printer's location should be carefully chosen because environmental conditions greatly affect its performance.

### Warning

- Confirm that the wall outlet is near the machine and freely accessible, so that in event of an emergency, it can be unplugged easily.
- Only connect the machine to the power source described on this manual.
- Avoid multi-wiring.
- Do not damage, break or make any modifications to the power cord. Do not place heavy objects on it, pull it hard or bend it more than necessary. These actions could cause an electric shock or fire.

### Caution

- Keep the machine away from humidity and dust. A fire or an electric shock might occur.
- Place the machine on a strong and level surface. Otherwise, the machine might fall and result in an injury.
- If you use the machine in a confined space, confirm that there is a continuous flow of air.

## 3 Power Connection

Connect the power cord to a power source with the following specifications:

- 120 V, 60 Hz, 11 A or more-

## 4 Space Required for Installing the Printer

Leave enough space around the printer. This space is necessary to operate the printer. The recommended (or minimum) space requirement is as follows:

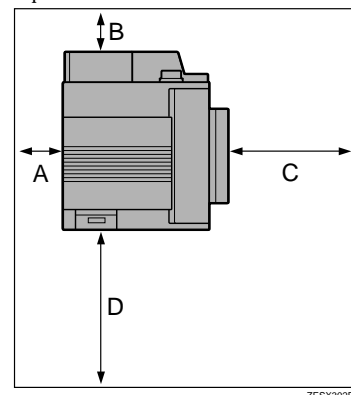

- A: 10 cm (4 inch) or more
- B: 10 cm (4 inch) or more
- C: 55 cm (22 inch) or more
- D: 75 cm (30 inch) or more

# 2

## UNPACKING THE PRINTER AND CHECKING THE CONTENTS OF THE BOX

### Caution

- To prevent an injury, this printer should be lifted by at least two people.

## 1

Check the contents of the box according to the following list. If one or some items are missing, please contact your sales or service representative.

### Important

- This package does not include an interface cable. Please purchase one for use with your host computer. See "Appendix" in the Administrator Reference.

- MANUALS FOR THIS PRINTER
  - Quick Installation Guide (This manual)
  - Maintenance Guide 1
  - Maintenance Guide 2
  - Option Setup Guide
  - CD-ROM "Printer Drivers and Utilities"
  - CD-ROM "Operating Instructions"
  - CD-ROM "Document Management Utility"
  - Development Unit Test Print
  - Power Cable
  - Ferrite Core
  - Fuser Oil Unit

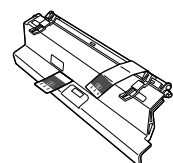

- Paper Feed Unit Labels

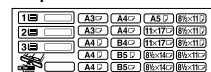

## 2 Remove the plastic bag.

## 3 Lift the printer and move it to the place where you want to install it.

When lifting the printer, pull out the holding handles from the sides of the printer, and hold them with at least two people.

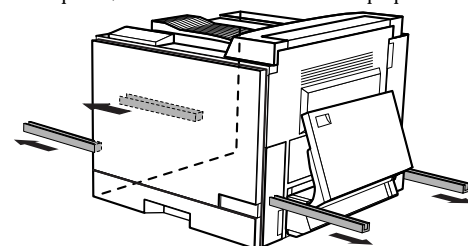

### Important

- When installing the printer to a low position, be careful not to get your hand or clothes caught under the printer.

## 4 Return the grips into the printer.

## 5 Remove adhesive tapes and packing materials from the printer.

## 6 Put the Paper Feed Unit label for Tray 1 on the front of Tray 1.

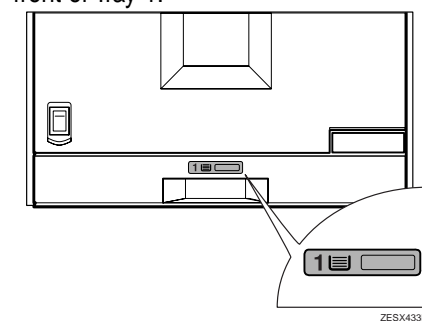

# 3

## PREPARING THE DEVELOPMENT UNIT

### Warning

- Do not incinerate spilled toner or used toner. Toner dust is flammable and might ignite when exposed to an open flame.
- Disposal should take place at an authorized dealer or an appropriate collection site.
- If you dispose of the used toner containers yourself, dispose of them according to the local regulations.

### Caution

- Do not eat or swallow toner.
- Keep toner (used or unused) and toner cartridges out of reach of children.
- Our products are engineered to meet the highest standards of quality and functionality. When purchasing expendable supplies, we recommend using only those provided by an authorized dealer.

## 1 Open the left cover of the printer by pulling the fasteners (1 ⇔ 2).

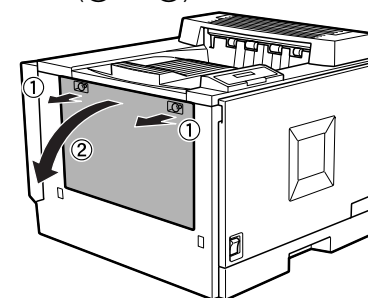

### Note

- The two round fasteners cannot be detached.

From the top, the development units are installed in the order of black, yellow, cyan, and magenta.

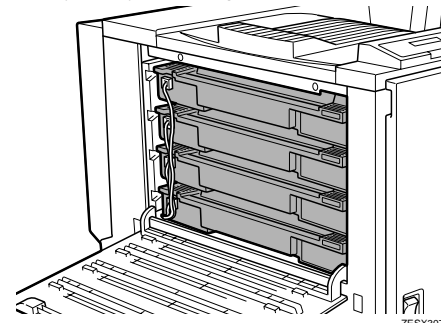

## 2 Remove all of the packing materials with red tags.

Four packing materials are connected together, and there are two of them. Remove one by one from the top of the units by holding the packing material, not the wire.

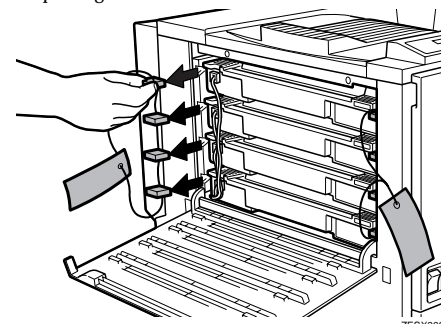

## 3 Detach the connectors from the development units from the top to the bottom by pressing the sides of the connectors.

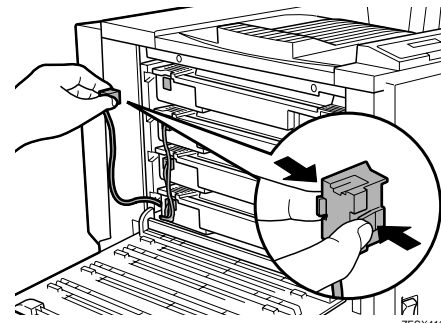

## 4 Follow steps 4 to 8 for each development unit individually. Remove the development unit by lifting it first as shown in the illustration (1 ⇔ 2).

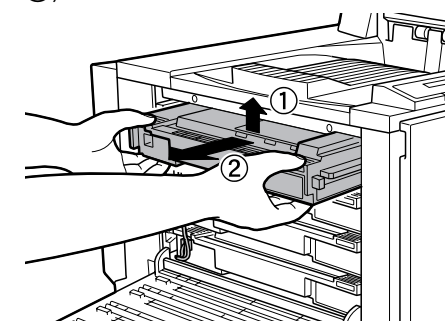

The illustration shows how to remove the black development unit. The procedure is the same for all four colors.

### Important

- Be sure to hold the unit with both hands, and then pull it slowly.

## 5 Hold the development unit, and then shake it about 10 times.

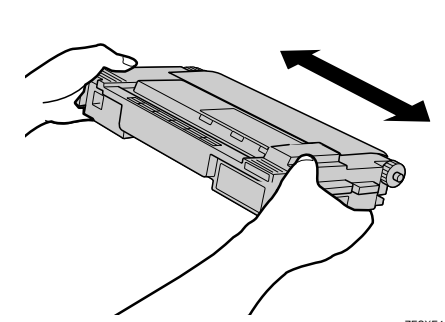

### Important

- Hold the unit with the roller facing down.
- Do not add shocks to the unit.
- If you do not shake the unit well, it may take longer for the machine to warm up when turned on.
- Do not touch the roller or the gears shown in the illustration.

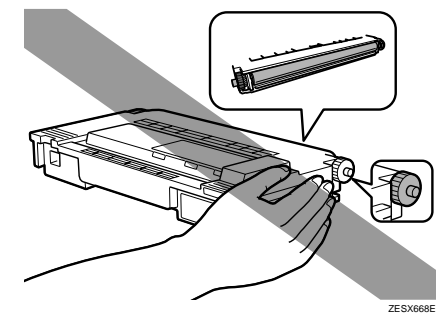

## 6 Set the development unit by aligning the guides, pushing towards direction (1), and then inserting slowly until it stops (2).

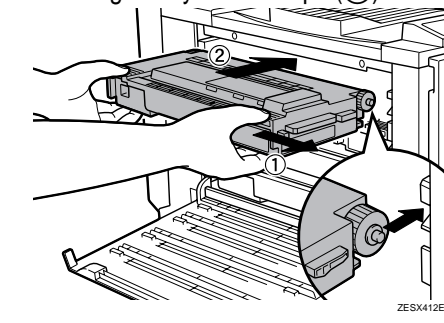

The illustration shows how to install the black development unit. The procedure is the same for all four colors.

### Note

- When installing the development unit, it may come out a little. This is not a malfunction.

## 7 Confirm the label for the color, and then confirm that the unit is securely fit in the stoppers.

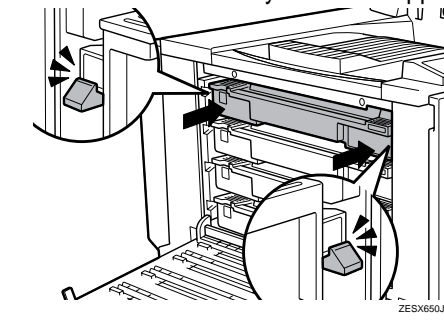

When there is a white line showing at the stoppers, reinsert the units.

### Important

- If the development unit is not installed properly, the printing quality may be poor.

## 8 Repeat steps 4 to 8 to set the rest of the development units.

## 9 Insert the connectors to the development units from the bottom (1) to the top (4) until they click into place.

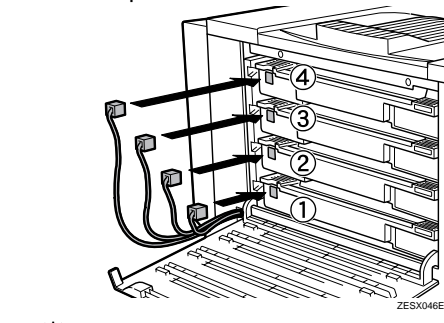

### Important

- Be sure that all four connectors are connected to the development units. Turning on the power without all four connectors connected to the units may cause a printer malfunction.

## 10 Close the left cover of the printer by pushing the fasteners (2) while holding the cover (1).

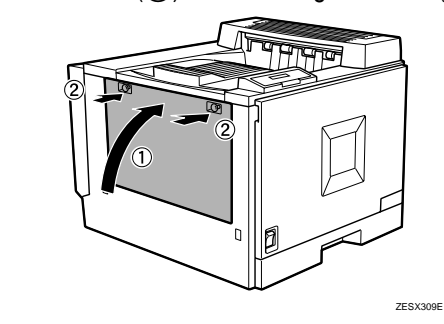

## 2 Environments to Avoid

### Important

- Locations exposed to direct sunlight or strong light
- Dusty areas
- Areas with corrosive gases
- Areas excessively cold, hot, or humid
- Locations near an air conditioner or humidifier
- Locations near other electronic equipment
- Locations where the printer might be subjected to frequent strong vibration



# 4

## INSTALLING THE FUSER OIL UNIT

### Caution

- Do not incinerate the oil bottle. This could cause a fire or an injury.
- Spilt oil is very slippery. If oil is spilt, wipe it up with an alkaline cleaner. Otherwise, the oily surfaces can create the danger of slipping and an injury.
- Do not pull out the fusing unit quickly. It may cause the unit to fall, and result in an injury.
- Do not open the front cover when the paper tray is pulled out halfway. If you do, it might cause an injury.

- 1 Open the front cover slowly by pulling down from the two areas on the left and right.

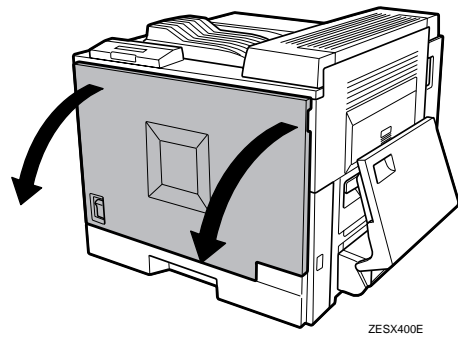

- 2 Remove the packing material.

- 3 Open the Bypass Tray.

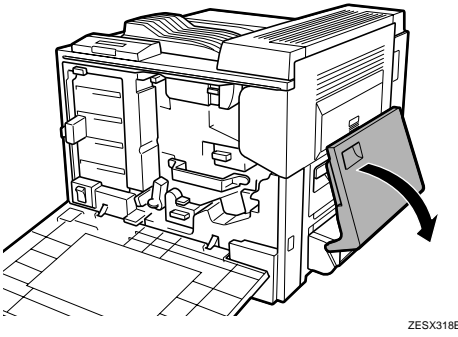

- 4 Open the right cover of the printer by pushing up the handle.

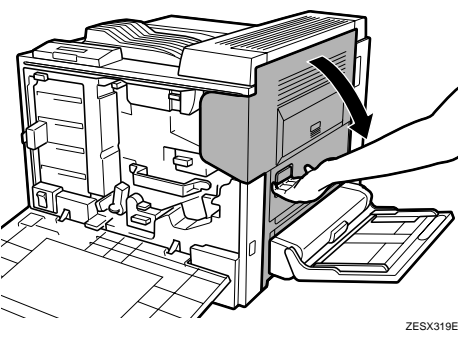

- 5 Remove the packing materials by holding the red tags as shown in the illustration.

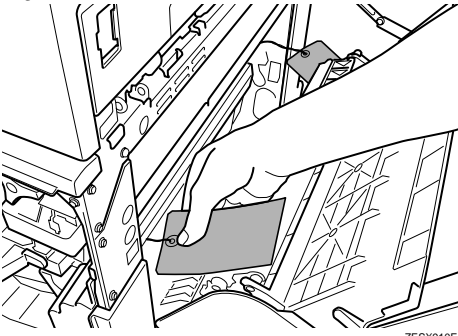

### Note

- There are two of them.

The fuser oil unit is placed on the fusing unit shown in the illustration.

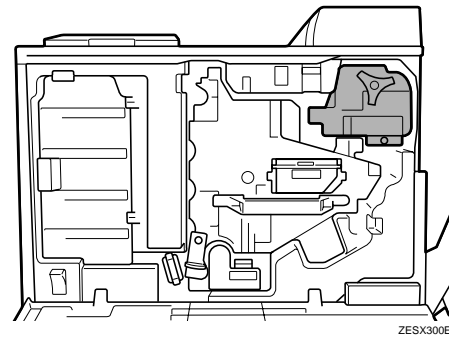

- 6 Release the green screw that is fastening the fusing unit.

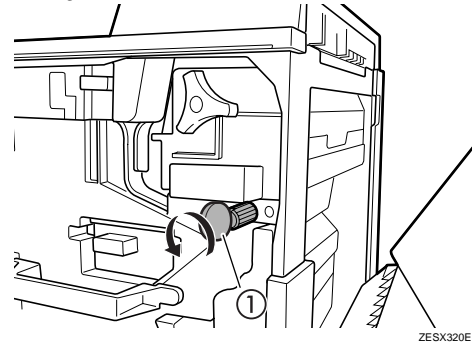

### Note

- Use a coin (1) to release the screw.
- The screw cannot be detached.

- 7 Holding the handle, pull the fusing unit slowly until it stops.

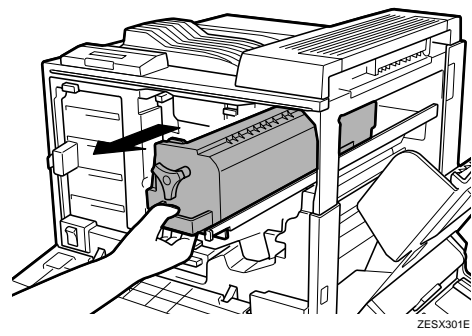

- 8 Take out the new fuser oil unit from the bag. Remove the covering paper, the seals, and then the fitting.

- 1 Remove the seal (1) by shaking it to pull.

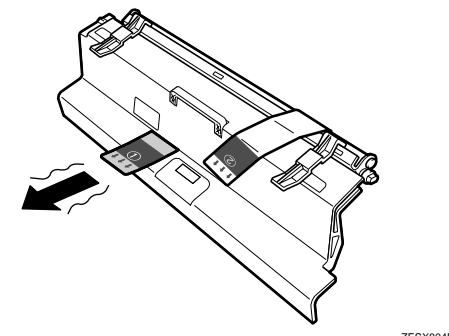

### Note

- If you cannot remove it easily, pull it out with a little force.

- 2 Remove the seal (2) slowly by turning the fuser oil unit.

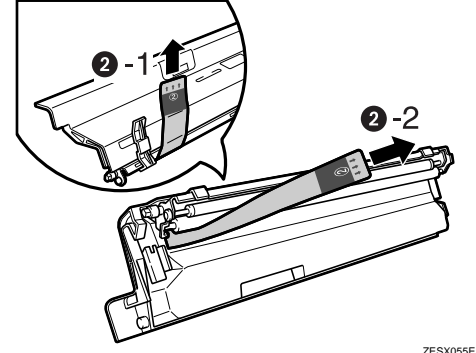

- 3 Remove the fitting.

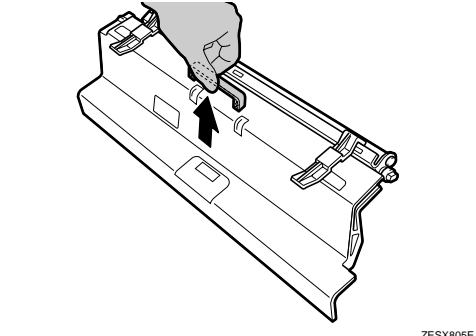

### Note

- Do not remove the two red fittings with the tapes until step 10.

- Be sure to remove the seals to avoid a printer malfunction.
- Be sure to remove the seal (1) first, and then remove the seal (2) to avoid an oil leak.
- Be sure to put the fuser oil unit in a stable and level place to avoid an oil leak.
- Oil is on the seals and fusing oil roller after removal. Be careful not to get it on your hands or clothes.

- 9 Holding the green part at the center of the fuser oil unit, align the shaft of the fuser oil unit with the metal holder of the fusing unit (1), and then set the fuser oil unit firmly by rotating it to the direction of the arrow (2).

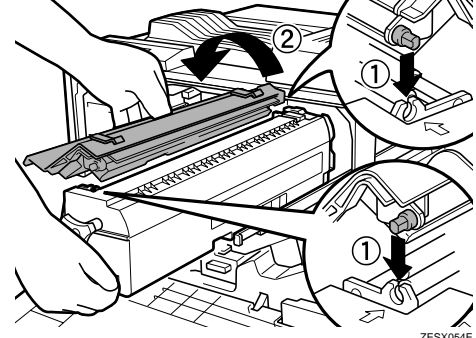

- 10 Remove the two red fittings along with the tapes from the fuser oil unit.

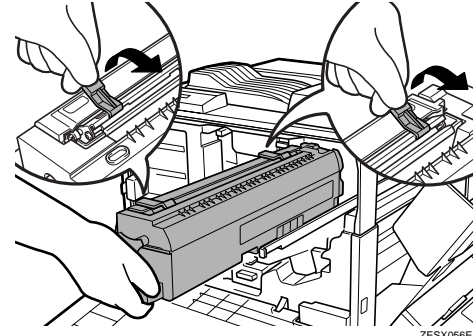

- 11 Holding the handle, insert the fusing unit slowly until it stops.

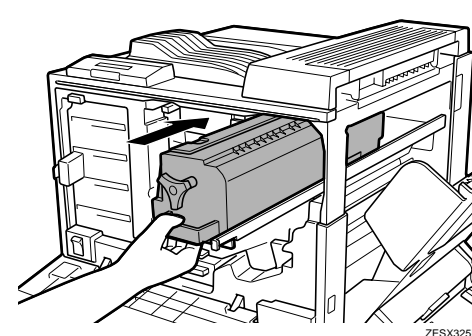

### Important

- Do not press the fusing unit forcefully into the printer, as it may cause a printer malfunction.

- 12 Fasten the green screw tightly using a coin (1).

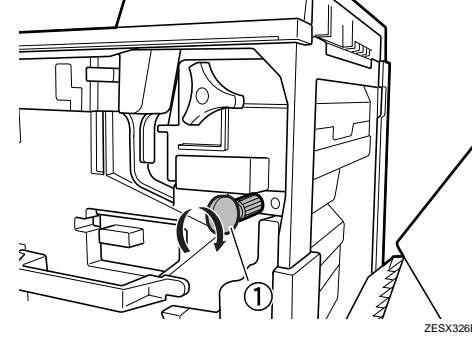

- 13 Close the right cover of the printer.

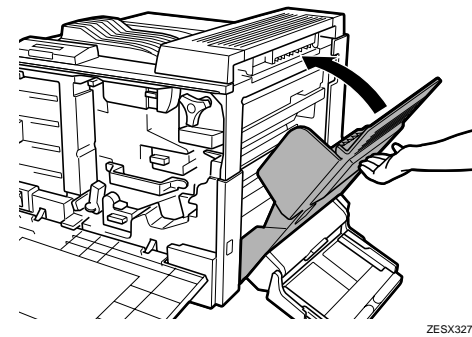

### Note

- Press "PUSH" to close the cover firmly.

- 14 Close the Bypass Tray.

- 15 Close the front cover slowly by pushing the two areas on the left and right.

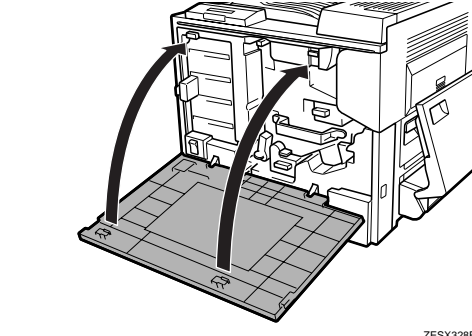

# 5

## LOADING PAPER

### Caution

- The paper tray does not have a stopper. When pulling it out, be careful not to pull it strongly. If you do, the tray might fall and cause an injury.

The following procedure describes how to load A4/letter paper.

For more information about the paper sizes that can be set in the paper tray, see "Paper Sizes" in Maintenance Guide 2 on the CD-ROM labeled "Operating Instructions".

For information about loading paper size other than A4/letter, see "Loading Paper" in Maintenance Guide 2 on the CD-ROM labeled "Operating Instructions".

For information about loading paper on the Bypass Tray, see "Loading Paper" in Maintenance Guide 2 on the CD-ROM labeled "Operating Instructions".

- 1 Pull out the paper tray slowly until it stops.

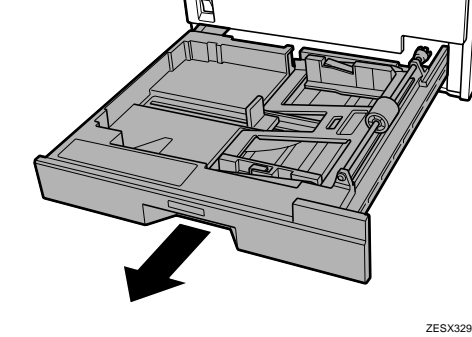

- 2 Lower the base panel by pushing "Push".

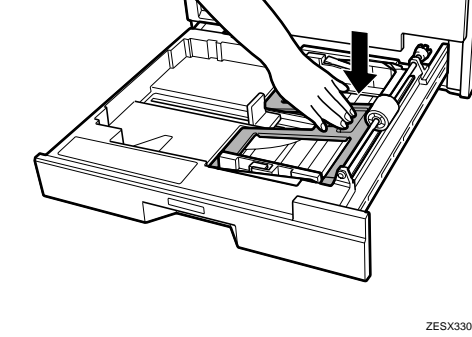

- 3 Load paper into the tray with the print side up.

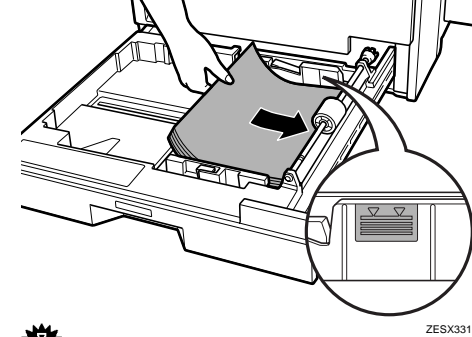

### Important

- Make sure that the top of the stack is not higher than the limit mark inside the tray.
- The front and side guides should be set exactly to the paper size to avoid paper misfeeds.
- Do not load different kinds of paper in the tray.

- 4 Slide the paper tray completely into the printer.

### Important

- Be sure to insert the paper tray completely. Otherwise, misfeeds might occur, or the front cover might touch the paper tray.

# 6

## CONNECTING THE POWER CORD

### Warning

- It is dangerous to handle the plug with wet hands. Doing this may result in receiving an electric shock.

### Caution

- When you pull the plug out of the socket, grip the plug, not the cord, to avoid damaging the cord and causing a fire or an electric shock.

### Important

- Be sure to connect the power plug to the socket or the wall outlet firmly.
- The printer power must be off when plugging in and out the power cord.

- 1 Confirm that the printer's power switch is off. If it is on, turn it off.

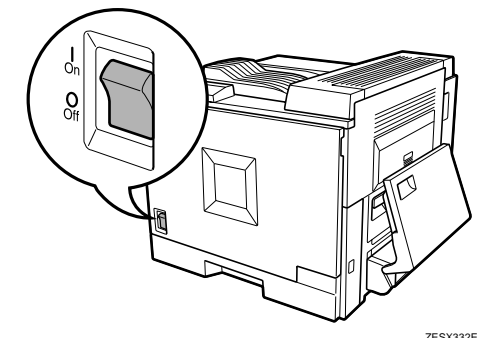

- 2 Attach the power cord to the rear of the printer, at the lower right.

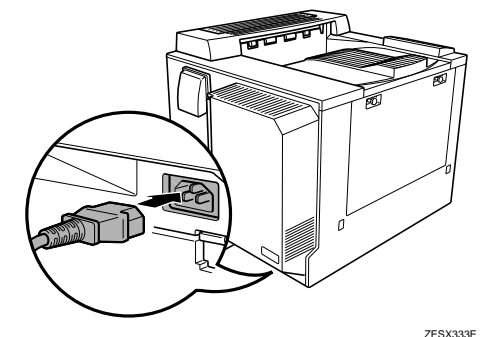

- 3 Plug the other end securely into the wall outlet.



Go to sheet 2/2.

# 7

## SELECTING THE PANEL DISPLAY LANGUAGE

Follow the procedure to select a language.

### Note

- You can select one of the following languages: English, German, French, Italian, Dutch, Swedish, Norwegian, Danish, Spanish, Finnish, Portuguese, Czech, Polish or Hungarian.
- The default setting is English.
- If you want to use the English panel display, it is not necessary for you to take the following procedures.

1 Turn on the printer.

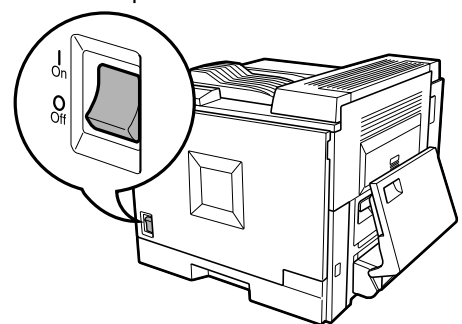

ZESX335E

When the power is turned on, the following message appears on the panel display for approximately 15 minutes while the machine is being warmed up.

Setting Up...  
[ > ]

Setting Up...  
[ > > ]

Setting Up...  
[ > > > ]

Setting Up...  
[ > > > > ]

Setting Up...  
[ > > > > > ]

After the machine warms up, "Ready" appears on the panel display.

Ready

2 Press [Menu].

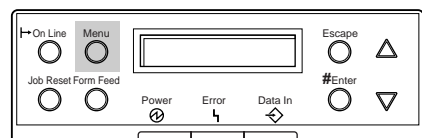

ZDJS100N

The following message appears on the panel display.

Menu:  
Paper Input

3 Press [▲] or [▼] to display "Language".

Menu:  
Language

4 Press [Enter #].

The following message appears on the panel display.

Language:  
\*English

5 Press [▲] or [▼] to display the language you want to select.

6 Press [Enter #].

"Menu" appears on the panel display.

Menu:  
Paper Input

7 Press [On Line].

"Ready" appears on the panel display.

Ready

# 8

## PRINTING THE TEST PAGE

You can check if the printer works properly by printing a test page such as the configuration page. However, you cannot check the connection between the printer and the computer by printing the test page.

1 Turn on the printer if it is not already on.

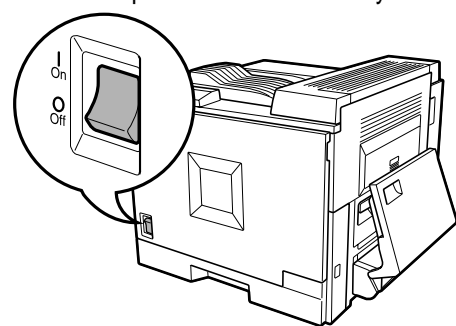

ZESX335E

It takes time before the machine warms up. See 7 "SELECTING THE PANEL DISPLAY LANGUAGE".

After the machine warms up, "Ready" appears on the panel display.

Ready

2 Press [Menu].

Menu:  
Paper Input

3 Press [▲] or [▼] to display "List/Test Print".

Menu:  
List/Test Print

4 Press [Enter #].

The following message appears on the panel display.

List/Test Print:  
Config.Page

5 Confirm that "Config.Page" is on the display, and then press [Enter #].

6 In a short time, the test printing will start.

Printing...

### Important

- If you cannot complete the test printing correctly, see if an error message appears on the panel display. For more information about error messages, see "Troubleshooting" in Maintenance Guide 2 on the CD-ROM labeled "Operating Instructions".

7 Press [On Line].

"Ready" appears on the panel display.

Ready

8 Press [Menu].

Print the sheet for checking the color condition to confirm the development units are properly installed.

9 Press [▲] or [▼] to display "Maintenance" on the panel display, and then press [Enter #].

Menu:  
Maintenance

10 Press [▲] or [▼] to display "Devp.Unit Check" on the panel display, and then press [Enter #].

Menu:  
Devp.Unit Check"

The following message appears on the panel display.

Press # to test  
print Devp.Unit

11 Press [Enter #].

Print out the sheet for checking the color condition.

Printing...

12 Use the sheet to check the print quality of each color.

If the printed sheet has no broken or blurred colors, the development units are installed properly. Go to 9, "CONNECTING THE PRINTER TO A COMPUTER".

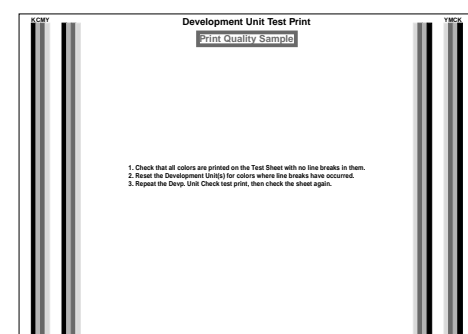

The development sheet that comes with the machine is a sample of correct print. If the test page's colors are blurred or broken compared to this sheet, turn the printer off, and then reset the development unit using the following procedure.

13 Open the left cover of the printer by pulling the fasteners (1) (2).

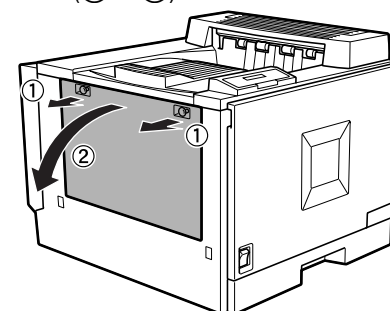

ZESX306E

### Note

- The two round fasteners cannot be detached. From the top, the development units are installed in the order of black, yellow, cyan, and magenta.

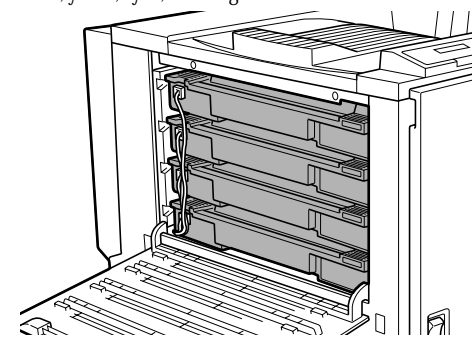

ZESX307E

14 Detach the connectors from the development units from the top to the bottom by pressing the sides of the connectors.

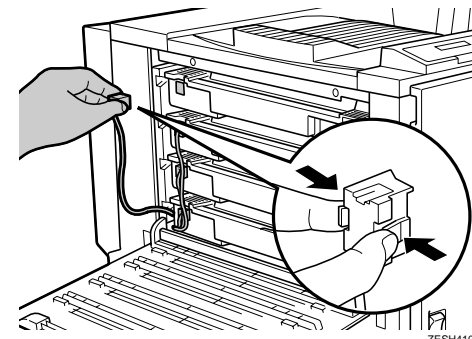

ZESX410J

15 Pull out the development unit partially (approximately 30mm (1)) by lifting it first as shown in the illustration.

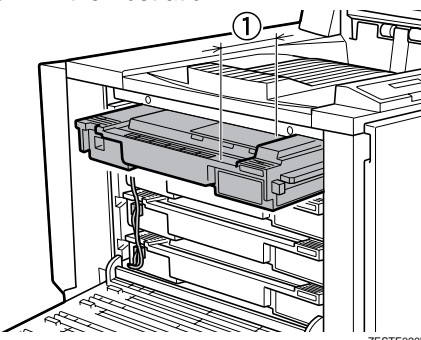

ZESTE020E

The illustration shows how to pull out the black development unit. The procedure is the same for all four colors.

### Important

- Be sure to hold the unit with both hands, and then pull it slowly.

16 Push the development unit slowly until it stops.

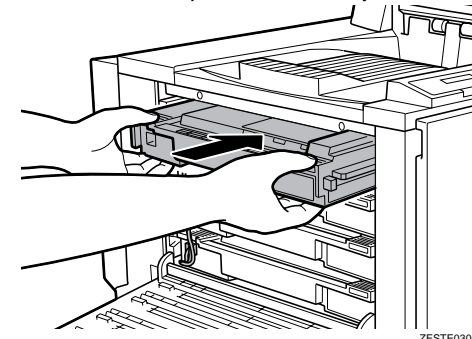

ZESTE030E

17 Confirm the label for the color, and then confirm that the unit is securely fit in the stoppers.

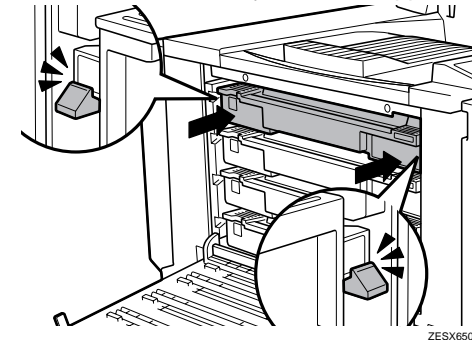

ZESX650J

When there is a white line showing at the stoppers, reinsert the units.

18 Insert the connectors into the development unit, until they click into place.

19 Repeat steps 7 to 12 to print the sheet for checking the color again and re-check the print quality.

### Important

- After installation, prints may exhibit a grainy sheen. However, this is not a malfunction. The sheen will disappear after printing 10 to 20 sheets.

# 9

## CONNECTING THE PRINTER TO A COMPUTER

❖ Connecting the printer to a computer using a network interface cable.

1 Check the LED is not lit, and then turn off the printer.

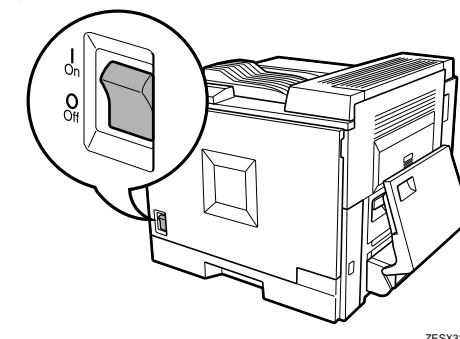

ZESX332E

2 Loop the network interface cable and attach the ferrite core.

### Note

- The network interface cable loop should be about 15 cm (6") (1) from the end of the cable (on the end closest to the printer).

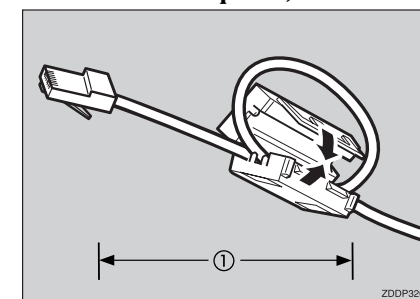

ZDJP020E

3 Connect the network interface cable to the ethernet port on the back of the printer.

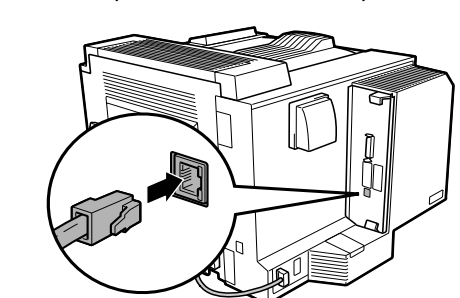

ZESX337E

4 Connect the other end of the cable to the network such as hub.

5 Turn on the printer.

6 Confirm the LEDs on the ethernet port.

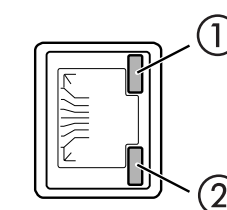

ZESX338E

① is lit when 100 BASE-TX is in use and not lit when 10 BASE-T is in use.

② is lit when the printer is securely connected to the network.

7 Go to 10 "CONFIGURING THE PRINTER FOR THE NETWORK".

# 10

## CONFIGURING THE PRINTER FOR THE NETWORK

❖ Connecting the printer to a computer using a parallel cable.

### Important

- ❑ The parallel cable is not provided with the printer. It is your responsibility to provide the parallel cable appropriate for the computer that you are using.
- ❑ The printer's parallel connection is a standard bi-directional interface. It requires a standard 36-pin parallel cable compliant with IEEE1284 and the parallel port on the computer.
- ❑ To avoid electrical interference, use a shielded cable.

### Note

- ❑ Do not use a parallel cable longer than 2.5 meters (8.2 feet).

1 Confirm that the printer's power switch is off. If it is on, turn it off.

2 Turn the computer off.

3 Attach the parallel cable to the port of the printer. Secure the cable with the metal fittings as shown in the illustration.

### Important

- ❑ Rating voltage of the parallel port for the computer: Max. DC 5V.

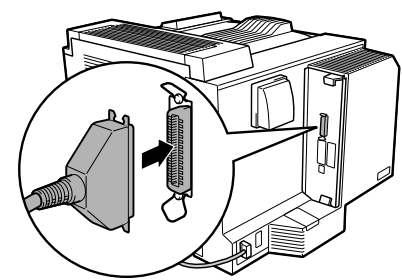

ZESK339E

4 Attach the other end of the parallel cable to the port of the computer. Secure the cable.

5 Turn on the printer and the computer.

6 Go to **11** "INSTALLING THE PRINTER DRIVER".

❖ Connecting the printer to a computer using a USB cable.

### Important

- ❑ The USB interface cable is not provided with the printer. Make sure that the USB interface cable you use, is appropriate for your computer.

1 Attach the USB interface cable to the USB interface connector of the printer. Secure the cable.

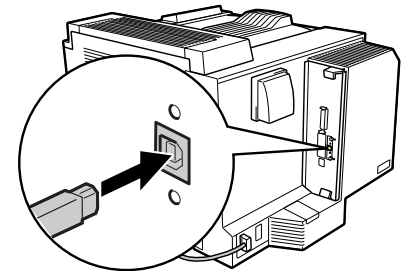

ZESKX00E

2 Attach the other end of the interface cable to the USB interface connector of the computer or the USB Hub. Secure the cable.

You must configure the printer setting using the control panel when using in a network environment. The following list is the items you can set and their default settings.

DHCP	On
IP Address	011.022.033.044
Subnet Mask	000.000.000.000
Gateway Address	000.000.000.000
Frame Type (NW)	Auto
Active Protocol	TCP/IP
Ethernet	Auto

The procedure below shows how to set the TCP/IP protocol. Make the settings for the other items by taking the same procedure.

1 Press [Menu].

"Menu" appears on the panel display.

Menu:  
Paper Input

2 Press [▲] or [▼] to display "Host Interface", and then press [Enter #].

Menu:  
Host Interface

The interface setting menu appears.

3 Start the protocol for use.

1 Press [▲] or [▼] to display "Network Setup", and then press [Enter #].

Host Interface:  
Network Setup

2 Press [▲] or [▼] to display "Active Protocol", and then press [Enter #].

Network Setup:  
Active Protocol

3 Press [▲] or [▼] to display "TCP/IP", and then press [Enter #].

Active Protocol:  
TCP/IP

4 Press [▲] or [▼] to display "Active", and then press [Enter #].

TCP/IP:  
\*Active

### Note

- ❑ \* shows the current setting.

In about two seconds, the display returns to the "Active Protocol" setting screen.

5 Set the rest of the protocols for use.

6 When all settings for the protocol are done, press [Escape].

The "Network Setup" setting screen appears.

### Note

- ❑ The default settings for all of the protocols are "Active".
- ❑ It is recommended to set the unused protocols "Not Active".

4 When you use this machine under DHCP environment, go to step 8. When you use this machine with a fixed IP address, you must make the setting for the required item after making the setting for DHCP Off. Go to step 5.

### Important

- ❑ When DHCP is On, you cannot make the setting for the following menus:

IP Address  
Subnet Mask  
Gateway Address

### Note

- ❑ Consult the network administrator for information about how to make the setting for the network

5 Make the setting for DHCP Off.

1 Press [▲] or [▼] to display "DHCP", and then press [Enter #].

Network Setup:  
DHCP

2 Press [▲] or [▼] to display "Off", and then press [Enter #].

DHCP:  
\*Off

### Note

- ❑ \* shows the current setting.

In about two seconds, the display returns to the "Network Setup" setting screen.

6 Set the IP address for the printer.

### Note

- ❑ Confirm the IP address to the network administrator.

1 Press [▲] or [▼] to display "IP Address", and then press [Enter #].

Network Setup:  
IP Address

The currently selected IP address appears.

### Note

- ❑ When [Enter #] is pressed, the cursor moves to the next field.
- ❑ When [▲] or [▼] is kept pressed for a few seconds, the value changes by 10.

2 Press [▲] or [▼] to set the value for the field.

IP Address:  
199.022.033.044

3 Press [Enter #].

The cursor moves to the next field.

4 Repeat 2 and 3 to set the value for the rest of the fields.

7 Set "Subnet Mask" and "Gateway Address" by following the same procedure for setting the IP address.

### Important

- ❑ The subnet mask is the mask value to use a part of the IP address as a network address. Confirm the value to the network administrator.
- ❑ The gateway address is the address of the host or router that acts as a gateway when interacting with work stations in another network. Confirm the value to the network administrator.

### Note

- ❑ If you are not sure of the setting addresses, leave them as default.

8 When all of the settings are done, press [On Line].

"Ready" appears on the panel display.

Ready

9 Print the configuration page to confirm the settings made.

See **8** "PRINTING THE TEST PAGE" for printing the configuration page.

# 11

## INSTALLING THE PRINTER DRIVER

You can install the printer drivers and software easily from the CD-ROM labeled "Printer Drivers and Utilities". Click [Quick Install] in the window of the CD-ROM to install PCL5c and RPCS printer drivers. To install the PostScript 3 printer driver, click the PostScript 3 printer driver button. For more information about the PostScript 3 printer driver, see the Administrator Reference or the Client Reference on the CD-ROM labeled "Operating Instructions" depending on the environment you use in. When the TCP/IP protocol is used, SmartNet-Monitor for Client will be installed as well.

The supported operating systems are Windows 95/98/Me, Windows 2000, Windows XP, and Windows NT 4.0.

When using with TCP/IP protocol, confirm the followings:

- ❑ The printer is connected to a network with the ethernet cable.
- ❑ The TCP/IP protocol is set.
- ❑ The IP address is set for the printer and the computer.

1 Insert the CD-ROM labeled "Printer Drivers and Utilities" into the CD-ROM drive.

Auto Run will start the installer.

2 Select a language to change the interface language, and then click [OK].

The following languages are available:

Cestina (Czech), Dansk (Danish), Deutsch (German), English (English), Espanol (Spanish), Francais (French), Italiano (Italian), Magyar (Hungarian), Nederlands (Dutch), Norsk (Norwegian), Polski (Polish), Portugues (Portuguese), Suomi (Finnish), Svenska (Swedish)

Default interface language is English.

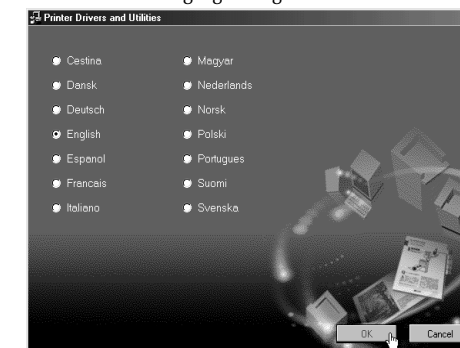

3 Select [Quick Install].

The software license agreement appears in the [License Agreement] dialog box.

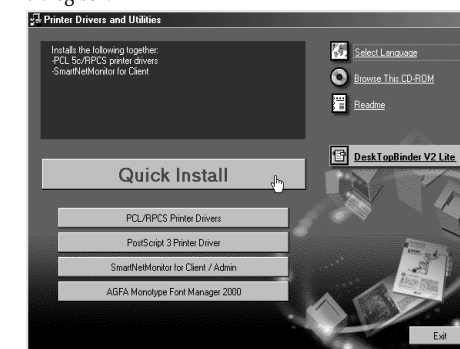

This is an example when English is selected in step 2.

4 After reading through all of the contents, click [I accept the agreement] to agree with the License Agreement, and then click [Next].

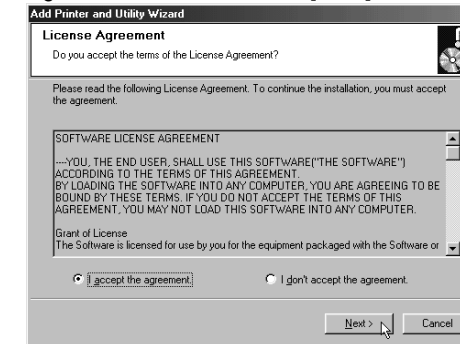

5 Select the printer model you want to install in the "Select Printer" dialog box.

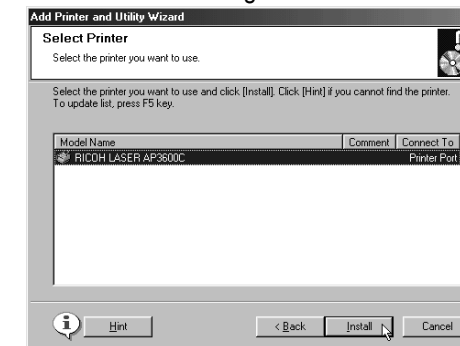

### Note

- ❑ For a network connection with TCP/IP, select the printer whose IP address is displayed in [Connect to].
- ❑ For parallel connection, select the printer whose printer port is displayed in [Connect to].

6 Click [Install].

The following display appears while installing the printer driver.

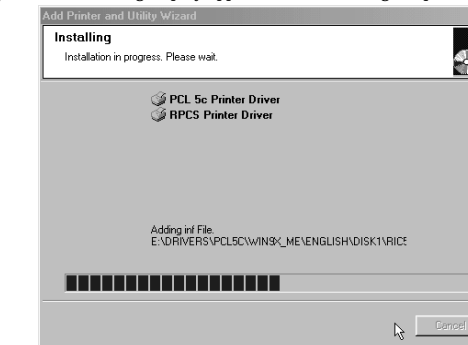

When finished, the [Installation Completion] dialog box appears.

### Note

- ❑ With Windows 2000, the [Digital Signature Not Found] dialog box may appear when installing the printer driver. In this case, click [Yes] to continue the installation.

7 Click [Finish].

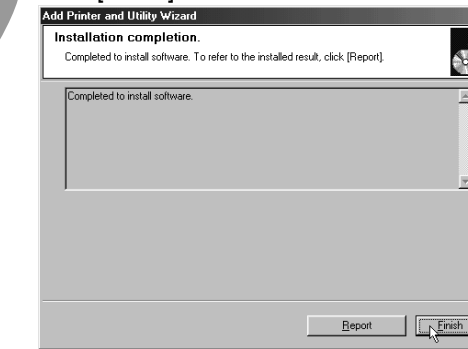

### Note

- ❑ A message directing to restart the computer may appear. In this case, restart your computer to complete the installation. When no such message appears, go to step 8.

8 Click [Exit].



The installation is now complete.